

460 Southport Commerce Blvd.
Spartanburg SC 29306
Phone: 864-574-6004
Toll Free: 1-888-532-2816

sales@ojedausainc.com
service@ojedausainc.com
www.ojedausa.com



REFRIGERATED MERCHANDISING SOLUTIONS

ALPA-series

Installation and Operation Manual

ALPA-36H

ALPA-55H *SLIM*

ALPA-55H

ALPA-77H *SLIM*

ALPA-77H

ALPA-99H

ALPA-120H *SLIM*

ALPA-120H

ALPA-120H *SS*

ALPA-180H



ALPA-120H *SLIM*



ALPA-36H



ALPA-77H



ALPA-99H

Part Number 100330038

www.ojedausa.com

TABLE OF CONTENTS

APPLICATION.....	3
PRODUCT REGISTRATION.....	3
DIRECTIONS FOR STORAGE AND HANDLING THE EQUIPMENT.....	3
STORAGE OF THE EQUIPMENT.....	3
UNCRATING.....	3
MOVING THE EQUIPMENT.....	4
PLACING AND INSTALLING THE EQUIPMENT.....	4
ELECTRICAL REQUIREMENTS.....	5
POSITIONING SHELVES.....	5
PRODUCT LOADING.....	5
UNIT OPERATION AND COMPONENTS.....	6
ELECTRONIC TEMPERATURE CONTROL.....	6
CAUTION.....	8
SHELF SPECIFICATIONS.....	8
MAINTENANCE GUIDELINES.....	8
MAINTENANCE GUIDELINES CONT'D.....	9
CLEANING DRAIN LINES.....	10
STANDARD WARRANTY.....	11
TECHNICAL ASSISTANCE.....	12

You have selected one of the finest commercial refrigeration units made. It is manufactured under strict quality controls with only the best quality materials available. Your Ojeda cooler when installed correctly and properly maintained will give you many years of trouble-free operation.

WARNING!

USE THIS APPLIANCE FOR ITS INTENDED PURPOSE AS DESCRIBED IN THIS MANUAL

When using electrical appliances, basic safety precautions should be followed, including the following:

- Use this appliance for its intended purpose as described in this Owner Manual.
- This refrigerator must be properly installed and located in accordance with the Installation Instructions.
- We strongly recommend that any servicing be performed by a qualified individual.
- Do not allow children to climb, stand, or hang on the shelves in the refrigerator. They could damage the refrigerator and seriously injure themselves.
- Do not store or use gasoline or other flammable vapors and liquids in the vicinity of this or any other appliance.
- Unplug the refrigerator before cleaning and making repairs.

WARNING Child Safety!!

Destroy carton, plastic bags, and any exterior wrapping material immediately after the freezer is unpacked. Children should never use these items for play. Cartons covered with rugs, bedspreads, plastic sheets or stretch wrap may become airtight chambers and can quickly cause suffocation.

A child might suffocate if he crawls into a freezer to hide or play. Remove the door of a freezer when not in use, even if you plan to discard the freezer. Many communities have laws requiring you to take this safety precaution. Remove and discard any spacers used to secure the shelves during shipping. Small objects are a choke hazard to children.

ADDITIONAL WARNING

- Please use care when moving or handling this equipment. It is equipped with flammable refrigerant and damage to refrigerant tubing will increase the risk of a leak.
- When service is required, seek factory authorized technicians trained to safely maintain and service systems that utilize flammable refrigerants, such as R290. RSES offers such training and certification.

Use factory authorized replacement parts to minimize the risk of possible ignition.

CAREFULLY READ THESE INSTRUCTIONS.

This manual provides instructions in how to best locate, operate, and maintain this equipment.

It is recommended to keep this manual for any future reference.

Detailed Warranty Guidelines can be found on the Ojeda website.

APPLICATION

The **ALPA-series** of coolers have a sanitation listing permitting the merchandising of packaged food and beverage product. The unit must be located in an indoor environment where the ambient must be maintained less than 75°F/55° RH.

PRODUCT REGISTRATION

Write down the Serial number of your new unit for future reference. The Serial Number is found on the data plate located on the back of the unit.

MODEL: _____

SERIAL NUMBER: _____

DIRECTIONS FOR STORAGE AND HANDLING THE EQUIPMENT

STORAGE OF THE EQUIPMENT

If the equipment will be kept in storage, it is suggested to keep it in its original packing. In case you need your equipment to be inactive for a long period of time after being used, verify that it has been unplugged. After cleaning it thoroughly with a damp cloth, lukewarm water and neutral soap and carefully drying it, cover it with a polyethylene film or similar waterproof material.

UNCRATING

The following procedure is recommended for uncrating the unit:

Remove the outer package by carefully cutting the shrink wrap and removing the 4 corner posts and top lid. Inspect for concealed damage. Immediately file a claim with the freight carrier if there is damage. Move your unit as close to the final location as possible before removing the wooden skid.

MOVING THE EQUIPMENT

The unit is constructed to facilitate using a forklift to handle it. (Fig. 1)
Use this handling means to move the equipment as close as possible to the location where it will be installed.

IMPORTANT: Never push, pull, or strike the front or side glass.

Fig. 1

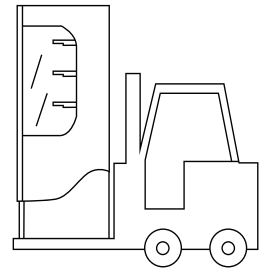

PLACING AND INSTALLING EQUIPMENT

ENVIRONMENTAL CONDITIONS

THIS UNIT CANNOT BE INSTALLED IN ENVIRONMENTS WITH EXPLOSIVE GASES.
THE EQUIPMENT IS DESIGNED ONLY FOR INDOOR OPERATION.

The unit must be located in an indoor environment where the ambient is maintained less than 75°/55° RH.

For the correct performance of the refrigerating system, it is very important to leave at least 4" (10 cm) of free space both at the sides and back to allow proper air circulation.

Care must be taken to ensure that air drafts around the cooler are kept to a minimum. A minimum space must be kept between the cooler and air sources such as air conditioner supply or return grilles, vent hoods, appliance condenser air intake and discharge, outside doors, fans, or other air movement devices (Fig. 2).

The following horizontal distance should be considered minimums unless special precautions are taken to prevent interruption of the **ALPA** air curtain:

- 5' from appliance condenser air intake and discharge
- 10' from air conditioner supply or return grilles
- 10' from vent hood
- 15' from open doors

The location of the cooler must be kept away from sources of heat and humidity including direct sunlight (Fig.3), toasters, ovens, coffee warmers, other appliances condenser air discharge, infrared heaters, or other heat generating appliances.

The unit should be leveled prior to operation.

The unit must have casters, 6" legs, or sealed per NSF guidelines as shown in Figure 4A and 4B.

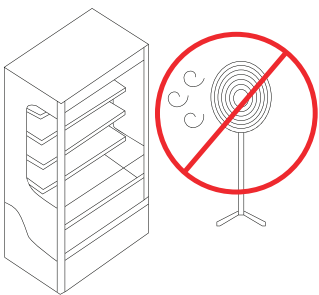

Fig. 2

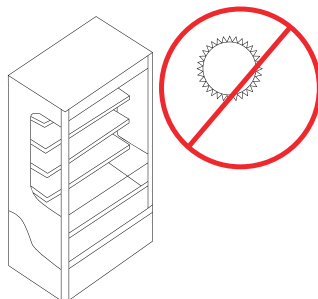

Fig. 3

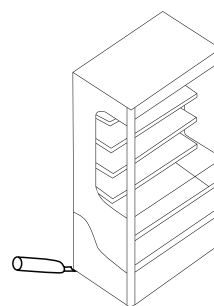

Fig. 4A

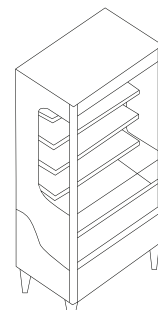

Fig. 4B

ELECTRICAL REQUIREMENTS

The power cord of this appliance is equipped with a 3-prong (grounding) plug which mates with a standard 3-prong (grounding) wall outlet to minimize the possibility of electric shock hazard from this appliance.

ALPA units require a dedicated outlet with the type of receptacle as shown in the chart. The use of extension cords is not permitted and will void the warranty.

Model	Voltage (V)	Current (A)	Circuit Required (A)	NEMA Config.
ALPA-36H	120	6	15	5-15P
ALPA-55H	120	8	15	5-15P
ALPA-77H	120	12	20	5-20P
ALPA-99H	120	12	20	5-20P
ALPA-120H	120	12	20	5-20P
ALPA-120H SS	120	12	20	5-20P
ALPA-180H	120	18	20	5-20P
ALPA-55H SLIM	120	10	15	5-15P
ALPA-77H SLIM	120	10	15	5-15P
ALPA-120H SLIM	120	12	20	5-20P

Before connecting your equipment, check that the electrical data on the data plate match your electrical output.

IMPORTANT NOTICE: PLUG THE EQUIPMENT INDEPENDENTLY TO A LOAD CENTER WITH AN APPROPRIATE CIRCUIT BREAKER ACCORDING TO THE NAMEPLATE AMPS.

POSITIONING SHELVES

The shelves and holders have been fixed to the inside floor of the unit to prevent their loss during transportation.

Insert the shelf brackets in the pilaster notches making sure they are at the same level such that the shelves remain horizontal.

IMPORTANT: The products on each shelf must leave three to five centimeters of free clearance.

PRODUCT LOADING

The **ALPA-series** of units are not intended to be a pull down refrigerator and as such the product must be loaded at their intended merchandising temperature.

Before loading products, allow the equipment to operate empty for at least two hours.

When loading products:

- Do not block the lower ventilation grille with the packages about to be loaded. (Fig. 5)
- Do not block the return vents that ensure a proper refrigerated air circulation. (Fig. 6)
- Do not over hang the shelf.
- Do not press the product against the rear wall.
- Never exceed the shelf weight limits. (See Shelf Specifications Pg.8)

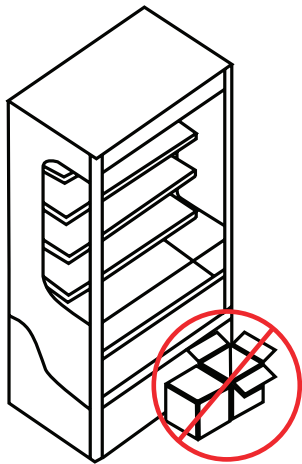

Fig. 5

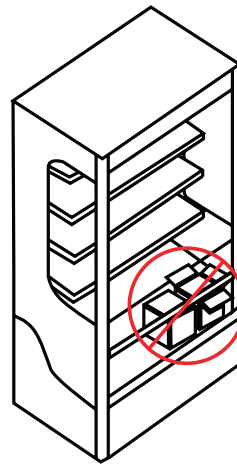

Fig. 6

UNIT OPERATIONS AND COMPONENTS

ELECTRONIC TEMPERATURE CONTROL

The unit is provided with an electronic temperature control that controls the operation of the unit based on the temperature of the air entering the evaporator at the front of the unit.

In order to achieve the desired product temperature, the electronic control is factory adjusted to turn off the refrigeration system at 35°F and start it at 39.5°F.

When you plug the unit in, the control display will illuminate. However, there is a start-up delay of 2 minutes before the compressor(s) are energized. This delay avoids the possibility that during a power failure the compressors are forced to restart before the refrigerant pressures are equalized.

The control has been factory-adjusted with a defrosting cycle scheduled to last 6 minutes every hour to ensure that the evaporator performs without any ice build-up.

None of the factory-programmed electronic control parameters can be modified unless an access code is entered (only your distributor's technical personnel have that code).

COMPRESSORS

The **ALPA-36H**, **ALPA-55H**, **ALPA-55H SLIM** and **ALPA-77H SLIM** have a single hermetic compressor. The **ALPA-77H**, **ALPA-99H**, **ALPA-120H**, **ALPA-120H SS**, **ALPA 120H Slim** and **ALPA-180H**, have two hermetic compressors that start in two steps with a delay of 10 seconds to reduce the in-rush of current to the unit.

CONDENSERS

The **ALPA** units incorporate a “maintenance free” condenser design in the refrigeration system which reduces the need for the regular cleaning process that fin and tube condensers require. Besides the savings in preventive maintenance costs, energy expenses will be stable throughout long periods of time since the condensers will remain “clean and unobstructed”.

EVAPORATOR

In the event it is believed that the unit has had a “freeze up” condition due to operation of the unit in high temperature or humidity conditions the evaporator can be inspected by removing the floor of the inside of the unit. In the event the evaporator is frozen, it can be thawed by emptying the cabinet of product and removing power until the coil is clear.

CONDENSATION EVAPORATOR TRAY

When the equipment operates, condensed water from the environment is collected on the evaporator. During each off-cycle, the water drains to the evaporator tray located at the bottom of the unit where it is evaporated using the heat from the refrigeration system.

SLIDING CONDENSING UNIT

The condensing unit can be pulled out, sliding it approximately 16” (40 cm) to allow servicing the condenser motor(s), compressor(s) and electrical components. In order to service the condensing unit, remove the two screws that hold the lower front grill (one at each side). Remove the screws that hold the front bracket that clasps the condensing unit and slide it gently out to have access to the components you want to check.

Once completed, every component must be returned to its original location for proper operation.

LIGHTING

The lamp can be turned off with the switch located at the left side of the upper section, near the lamp.

NIGHT CURTAIN

The night curtain should be pulled closed whenever the unit is not required for the active merchandising of product.

CAUTION

The equipment has been exclusively designed to maintain the proper temperature of packaged fresh food and beverages. Because the unit is not designed to cool the product down quickly, the product must be loaded at its appropriate temperature.

- Do not remove grilles or panels that require using tools to be accessed.
- Do not keep the unit running unloaded. **UNPLUG IT** when you are not planning to use it.

Using any electrical or electronic equipment entails the compliance with some fundamental rules.

- Do not touch the unit with wet hands or feet.
- Do not install the equipment outdoors.
- Do not remove or ignore safety devices.
- Do not leave objects on top of the unit.
- Do not climb on top of the unit.
- Never use direct or indirect water jets on the unit.
- Do not allow the electronic control to be adjusted by customers or unqualified personnel. For any adjustment you must contact your distributor.
- Verify that the hot air stream from the condenser towards the back of the unit is not directed to other refrigeration units, which would compromise their operation.
- Under no circumstance should you block the front grille of the unit.

THE MANUFACTURER DOES NOT ASSUME ANY RESPONSIBILITY ARISING FROM DAMAGES CAUSED BY IMPROPER, INCORRECT, OR ERRONEOUS USE.

It is important to instruct the user on the operation of the equipment according to this instruction manual, and to make sure that said manual is within reach of any operator that might use the unit.

SHELF SPECIFICATIONS

The shelves have been designed to withstand the rigors of normal use and loading with the following not to exceed evenly distributed weight per shelf:

ALPA-36H: 60 lbs (27 k).

ALPA-55H Slim, ALPA-55H, ALPA-77H Slim, ALPA-77H: 110 lbs (50 k).

ALPA-99H, ALPA-120H Slim, ALPA-120H, ALPA-120H SS, ALPA-180H: 132 lbs (60 k).

This load limits must not be exceeded to prevent potential damage to the shelf and/or injury to users.

MAINTENANCE GUIDELINES

Regularly and carefully cleaning the equipment prevents deterioration and product alteration.

CLEANING THE UNIT

Clean every week with only a damp piece of cloth and neutral soap each external and internal surface, and dry them with a clean soft cloth.

Never use flammable or abrasive products. The unit must never be cleaned with water jets.

IMPORTANT: During maintenance and cleaning operations, make sure that good visibility conditions exist in the working area, using other light sources in case it is needed. Be very careful when working with moving and/or high-temperature parts.

CLEANING THE CONDENSER COIL

IMPORTANT WARRANTY INFORMATION:

Condensers accumulate dirt and require regular cleaning. Dirty condensers result in compressor failure, product loss, and lost sales; which are not covered by warranty.

If you keep the condenser(s) clean you will minimize your service expense and lower your electrical costs. The following is a step-by-step guideline for the cleaning of the condenser(s):

1. Disconnect power to the unit.
2. Take off front lower grill assembly by removing the two (2) screws in the top corners.
3. Clean off accumulated dirt from the condenser coil(s) using a vacuum and/or a damp rag.
4. Replace the grill assembly.
5. Connect power to the unit and verify that when required the condensing unit(s) are running.

If you cannot remove the dirt adequately, please call your refrigeration service company.

CLEANING DRAIN LINES

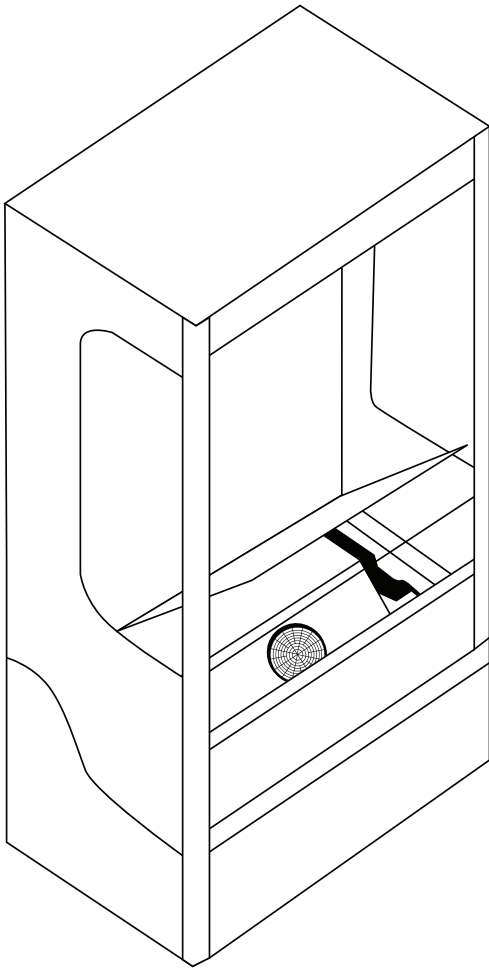

Fig. 7

Over time it is likely that the drain lines will become clogged which will result in water overflowing the condensate pan and onto the floor. This is a standard maintenance item and will not be covered under warranty.

The drain lines can also be accessed by removing the bottom panel from the inside of the unit. (Fig. 7). Both holes for the drain lines can be located (Fig. 8).

Obstructions can be removed either by compressed air or nitrogen, or physically removing the obstruction with a drain cleaner.

DO NOT USE A CHEMICAL DRAIN CLEANER AS THIS WILL VOID THE WARRANTY AND POSSIBLY DAMAGE THE UNIT.

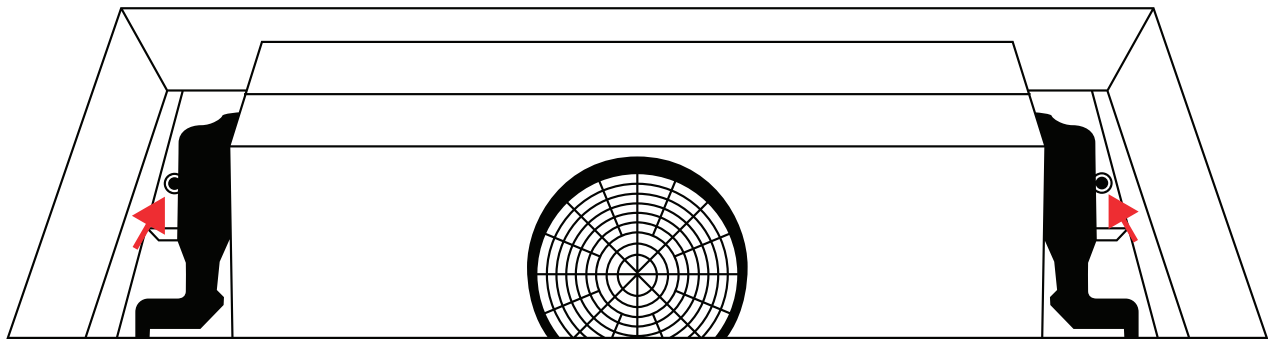

Fig. 8

Before calling for service, review this list. It may save you both time and expense. This list includes common occurrences that are not the result of detective workmanship or materials in this appliance.

<u>OCCURRENCE</u>	<u>SOLUTION</u>
Unit does not run	Check to ensure that unit is not plugged into a circuit that has ground fault interrupt. If you are unsure about the outlet, have it checked by a certified technician. Main Power switch is in the OFF position. Unit may not be plugged in, or plug may be loose. Be sure plug is tightly pushed into electrical outlet. House fuse has blown, or circuit breaker has tripped. Check/reset circuit breaker, or replace fuse with 15 AMPS. Time delay fuse. Power outage. Check house lights. Call local electric company.
Unit runs too much or too long	Room or outside weather is hot. It is normal for the unit to work harder under these conditions. Unit had recently been disconnected for a period of time. Unit requires 4 hours to cool down completely. Large amounts of warm or hot product have been stored recently. Warm product will cause the unit to run more until the desired temperature is reached.
Temperatures inside the unit are too warm	Unit has recently been disconnected for a period of time. Unit requires 4 hours to cool down completely.
Louder sound levels when compressor comes on	Unit operates at higher pressures during the start of the ON cycle. This is normal. Sound will level off or disappear as unit continues to run.

If technical personnel assistance is required, you must immediately contact your distributor, specifying the kind of problem and clearly indicating the equipment model and serial number. If replacing parts is required, do it through your distributor.

WARNING: Always ask for original spare parts

AUTHORIZED DISTRIBUTOR:

COMMERCIAL NAME:

ADDRESS:

TELEPHONE:

E-MAIL:
