

Project: _____
 Model #: _____
 Item #: _____ Qty: _____
 Approval: _____

460 Southport Commerce Blvd.
 Spartanburg SC 29306
 Phone: 864-574-6004
 Toll Free: 1-888-532-2816
 sales@ojedausainc.com
 service@ojedausainc.com
 www.ojedausa.com



OPEN AIR MERCHANDISER ALPA-120H-DS



Custom Graphics Available Upon Request

CARE FREE CONDENSER

The finless spiral condenser design prevents dust/dirt buildup allowing maximum long term efficiency.

R-290 REFRIGERANT

Equipped with R-290 refrigerant, an eco-friendly alternative that meets the EPA's environmental impact regulations.

STEEL CONSTRUCTION

Robust steel construction minimalizes the use of plastic materials resulting in an environmentally friendly design.

120 VOLT SYSTEM

All Alpa models feature a 110/120 Volt system standard, ensuring hassle-free plug and play for our customers.

ELECTRONIC CONTROL

The intelligent temperature control is programmed to ensure the correct operation of the equipment.

LED LIGHTED SHELVES

LED provides long lasting energy efficient lighting with minimal heat output.

HOT GAS EVAPORATION

Hot gas heated drain pan for condensate evaporation that reduces the need of floor drains or electric heaters.

GLASS MIRROR ENDS

Ideal for showcasing your products, our glass ends provide the perfect combination of style and functionality!

OPERATION TEMPERATURE

Medium Temp: 34°F to 40°F.

Dimensions			Shelves	HP	Voltage	NEMA Config	Amps	Crated Weight	Refrigerant
W	D	H							
52.1"	30.8"	79.9"	5	2x1/3	120	5-20P	12	652 lbs	R-290
1323 mm	782 mm	2029 mm	Net Capacity (cf): 32		Energy Consumption: 18.10 kWh/24 h				

*Inches rounded up one decimal place. *Specifics may change without notification.

OPEN AIR MERCHANDISER

ALPA-120H-DS

CABINET CONSTRUCTION

- High-density, CFC-Free, polyurethane insulation.
- Mirror ends provide enhanced product visibility.
- Manual retractable night curtain for increased energy savings.
- Exterior: Galvanized metal cabinet with powder coated painted surface.
- Interior: Easy to clean pre-painted steel.

SHELVING

- 5 adjustable dual-position LED lighted shelves with tag molding.
- Dimensions per shelf: 47.7" W x 16.3" D.

OPERATING CONDITIONS

- The unit is best suited for an environment where temperatures remain below 75°F and humidity does not exceed 55%.
- Open Air models should not be installed in any area where the air curtain will be disrupted. This includes placement near any HVAC vent, open doorway, fan or areas with direct sunlight.

ELECTRICAL

- 110/120 standard volt system.



LIGHTING

- LED lighted shelves.

REFRIGERATION

- R-290 refrigerant.
- Maintenance free condenser.
- Dual refrigeration system.
- Hot gas heated condensation pan.
- Electronic temperature control.
- Automatic defrost cycle.
- Easy to reach components for maintenance.

ACCESSORIES

- 3" or 5" casters.
- 6" stainless steel legs.
- Custom graphics.
- Front product merchandiser.
- Glass Doors.
- Lighted header.
- Lockable security cage.
- Peg bar system for hanging product.
- Reach-In Curtain.
- Shelf product retainers.

OPTIONAL ACCESSORIES

3"/5" CASTERS



DIMENSIONAL DRAWING

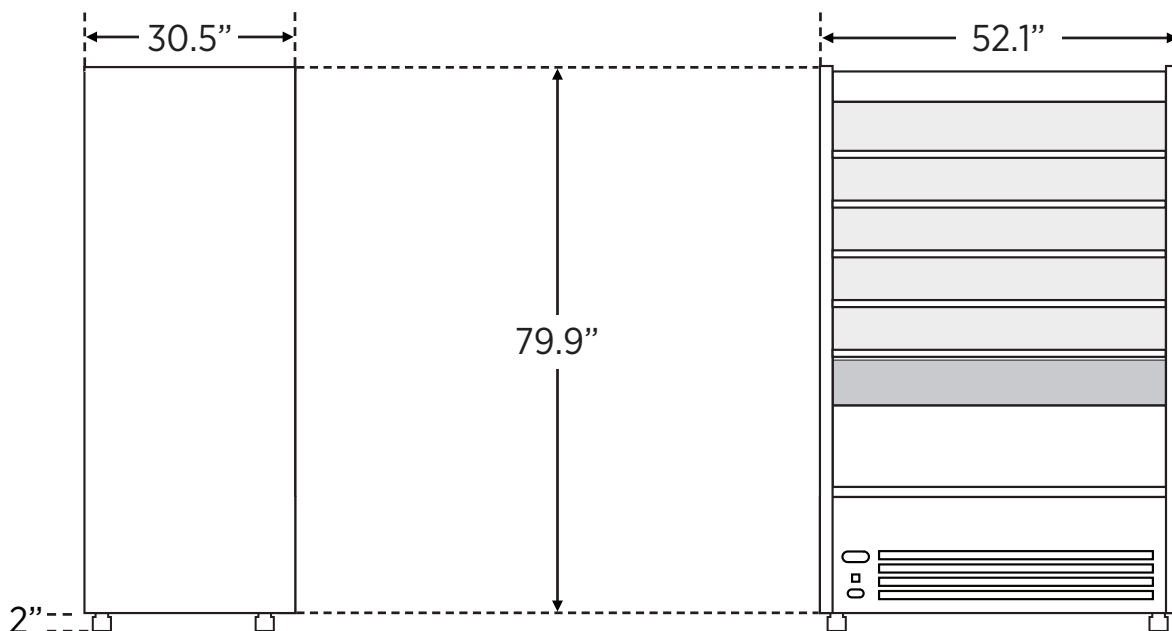

*Inches rounded up one decimal place. *Specifics may change without notification.



www.ojedausa.com